

Steam condensing unit



	Page
Introduction, scope, disclaimer	3
Safety information	4
Nomenclature	6
Features & benefits	6
CDU layout	7
Bill of materials	7
NextGen CoreSense	10
Electrical connections	16
CDU performance / technical data	20
Installation & start-up	22
Commissioning report	27

Introduction

Copeland stream condensing unit comes with state-of-the-art stream semi-hermetic compressors equipped with discus valve technology and new generation CoreSense module.

This document is designed to help the contractor and customer for the installation, commissioning & operation of Copeland's stream condensing unit.

Scope of supply – Check page number 10 of this manual for detailed scope of supply.

Disclaimer

Thank you for purchasing the Copeland stream condensing unit. We hope that this product meets your intended refrigeration requirement. Please read through this operation manual to familiarize yourself with the installation, commissioning and operation of this product. Please do read the following information in this page before proceeding with the rest of the manual.

The Copeland stream semi-hermetic refrigeration condensing units should only be installed by suitably qualified and experienced refrigeration technicians. No responsibility can be accepted for damage caused by inexperienced or inadequately trained site technicians or improper system design. All instructions and procedures described in this manual are based on good refrigeration trade practices as applicable to this particular product. The installation contractor may prefer to use variations to these recommendations. However, the methods described in this manual represent the minimum requirements to avoid any subsequent warranty claims for this equipment and its components. These instructions do not cover the fundamentals of good electrical or refrigeration practice and are therefore intended for use only by qualified and/or experienced personnel or technicians.

For any additional query, please consult your local sales office, quoting unit model and serial number as shown on the nameplate. In case of ambiguity, the wiring diagram supplied with each unit takes precedence over the diagram in this manual.

1. Safety information







1.1

Installation and commissioning work on CDU shall be carried out only by qualified, refrigeration personnel who have been trained and instructed.

1.2

Stream condensing unit is manufactured according to the latest safety standards. Emphasis has been placed on the user's safety. For relevant standards please refer to the manufacturer's declaration, available on request. You are strongly advised to follow these safety instructions.

1.3 Icon explanation

 WARNING This icon indicates instructions to avoid personal injury and material damage.	 CAUTION This icon indicates instructions to avoid property damage and possible personal injury.
 HIGH VOLTAGE This icon indicates operations with a danger of electric shock.	 IMPORTANT This icon indicates instructions to avoid malfunction of the compressor.
 DANGER OF BURNING OR FROSTBITE This icon indicates operations with a danger of burning or frostbite.	NOTE This word indicates a recommendation for easier operation.
 EXPLOSION HAZARD This icon indicates instructions operations with a danger of explosion.	

1.4 Safety statements

- Only qualified and authorized refrigeration personnel are permitted to install, commission and maintain this equipment.
- Electrical connections must be made by qualified electrical personnel.
- All valid standards for connecting electrical and refrigeration equipment must be observed.
- The national legislation and regulations regarding personnel protection must be observed.



Use personal safety equipment. Safety goggles, gloves, protective clothing, safety boots and hard hats should be worn where necessary.

1.5 General instructions

Warning



System breakdown! Personal injuries! Never install a system in the field and leave it unattended when it has no charge, a holding charge, or with the service valves closed without electrically locking out the system.

System breakdown! Personal injuries! Only approved refrigerants and refrigeration oils must be used.

Warning



High shell temperature! Burning! Do not touch the compressor until it has cooled down. Ensure that other materials in the area of the compressor do not get in touch with it. Lock and mark accessible sections.

Caution



Overheating! Bearing damage! Do not operate compressors without refrigerant charge or without being connected to the system.

Caution



Compressors contain oil & refrigerant under pressure. Release pressure from both high & low side of compressor before servicing.

Caution



Tube brazing & compressor operation can produce hot surfaces. To avoid burns, allow surfaces to cool.

1.6 Safety refrigerants/lubricant

- a. Please use correct refrigerant as designed to work in safe operating envelope.
- b. Compressor is supplied with an initial oil charge. The standard oil charge for use with HFC refrigerant is polyolester (POE) lubricant Emkarate RL 32 3MAF.

2. Nomenclature

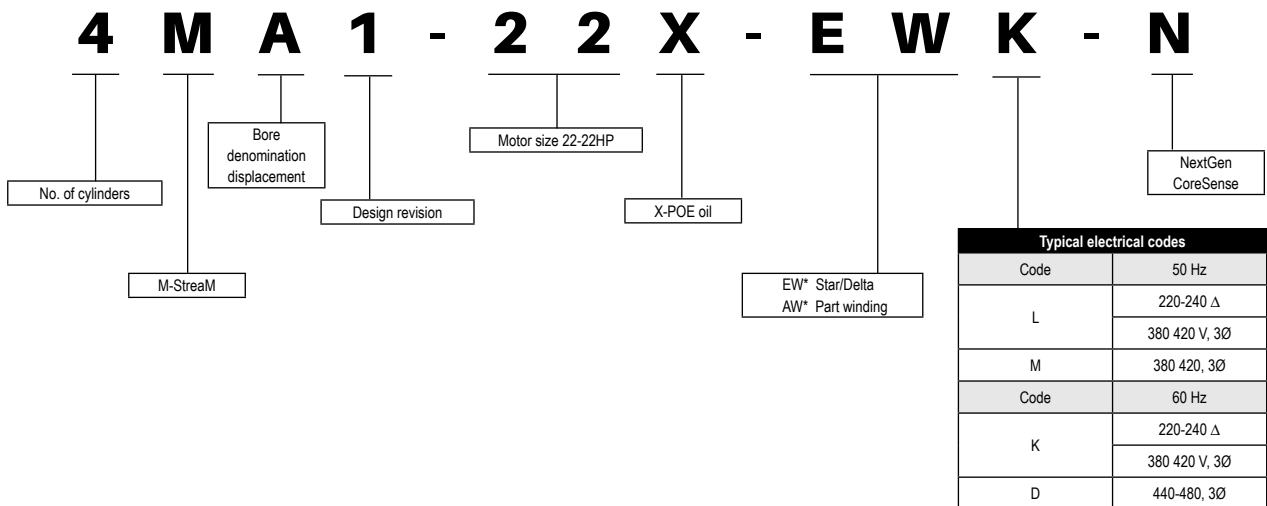

3. Features and benefits

Features	Benefits
Stream semi-hermetic compressor with CoreSense diagnostics	<p>Stream's unique discus valve technology makes it more efficient than other equivalent compressor and therefore helps reduce the carbon footprint and running cost of any installation.</p> <p>CoreSense module offers advanced protection and diagnostics benefits for excellent system reliability, reduced service costs and increased equipment uptime.</p> <p>Stream range provides best in class performance for today's commonly used HFCs and future low GWP refrigerants. This results in significantly lower cost of operation and reduced environmental impact compared to competing products.</p>
Condenser	Generously sized for high ambient operation
Accessories	<p>Liquid receiver</p> <p>Alco PS2 HP/LP cut-out for safety</p> <p>Hermetic moisture Indicator (optional)</p> <p>Filter drier (optional)</p> <p>Oil separator (optional)</p> <p>Accumulator (optional)</p>

4. Condensing unit layout

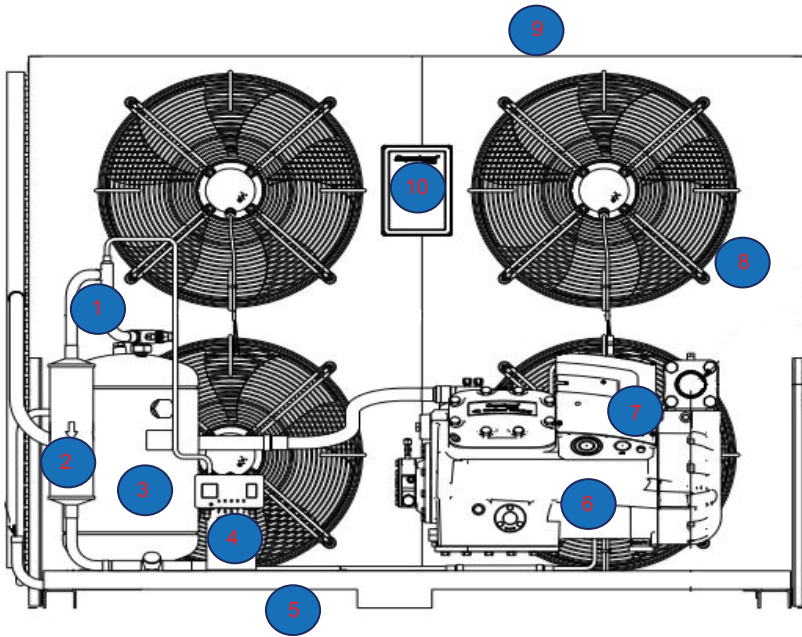

Item	Description
1	Service / shut-off valve
2	Filter drier (optional)
3	Liquid receiver
4	HP/LP cut-out
5	Base-frame
6	Stream compressor
7	CoreSense diagnostic module
8	Fans
9	Condenser
10	Junction box

5. Bill of materials

Nomenclature	Option
F00	Standard
F01	Filter drier and hermetic moisture indicator fitted on the liquid line
F02	Filter drier, hermetic moisture indicator and oil separator fitted on the liquid line
F03	Filter drier, hermetic moisture indicator and oil separator fitted on the liquid line including suction accumulator

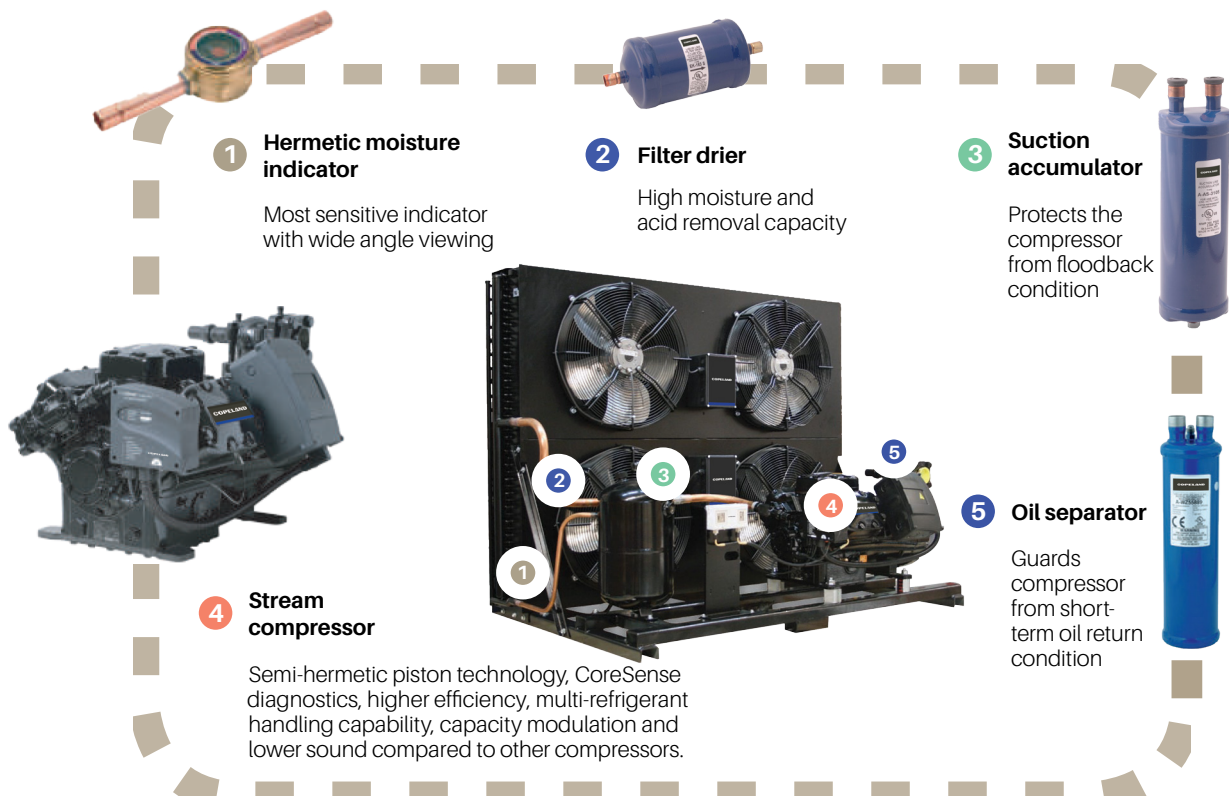

a. Stream compressors

- All stream compressors are suction gas cooled. (motor is cooled by refrigerant gas that is led over the motor).
- All compressors are fitted with discus valve plates.
- Each cylinder head has 2 plugged 1/8" - 27 NPTF tapped holes for connecting high pressure switches.
- Copeland stream compressors is fitted with CoreSense module as a standard.

b. Liquid receiver

- Copeland CDUs are equipped with liquid receivers
- Rotalock service valve is provided at the receiver outlet
- Sight glass mounted on liquid receivers to help to not exceed maximum liquid level

c. HP/LP cut-out

- Dual HP/LP, auto reset, safety switch
- Pressure switches used for control/protective functions
- Control functions – compressor cycling, pump down
- Protective functions – pressure limiting and cut-out against excessive pressures, against loss of charge or freeze protection
- Display scales are printed in relative pressure units – “bar” and “psi”

d. Z9/Z12 condenser

- Condenser is constructed with copper tubes and aluminum fins, steel-sheet housing with a fan opening.
- Number of fans: 4

e. Fan

- Z9 CDU is equipped with single phase fans and dual rated for 50/60 Hz operation.
- Fan is made of an external rotor motor with fan blades permanently fixed to rotor.
- Fan guard has 4 mounting feet.
- Fan is positioned in order to blow air from condenser to the compressor.

f. Mounting parts

To minimize vibration and start/stop impulses flexible mounting should be used. Each Stream compressor is delivered with four colored mounting springs that are installed between the feet and the condensing unit base plate. These are clamped to avoid transport damage. It is necessary to remove the transport clamps and to adjust the mounting spring height before starting up the condensing unit. The adjustment is described in the picture below.

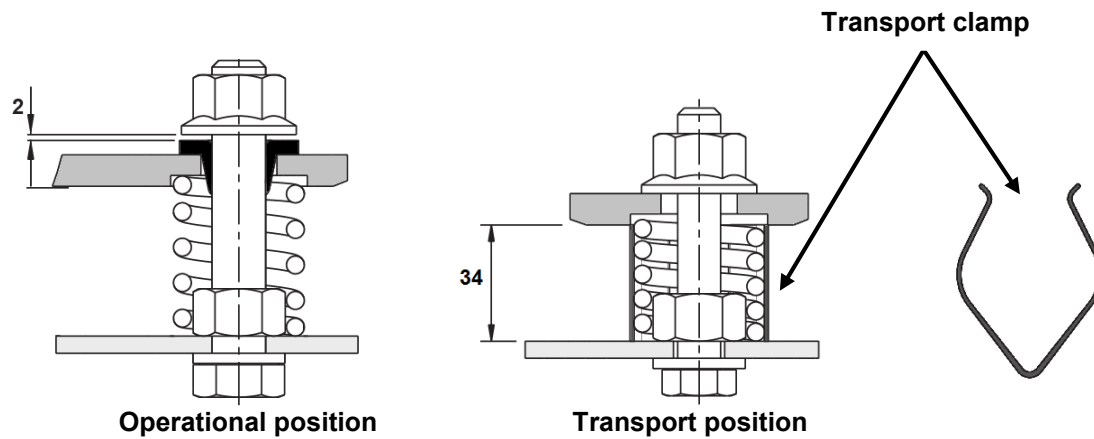

Due to differences in weight (cylinder / motor side) different springs have been used on both sides. Springs have different colours for easier identification: violet on motor side and orange on cylinder side.

g. Packaging



Condensing units are individually packed on a baseboard and a carton is fitted over. Accessories are mounted. In the unlikely event that the packaging box is damaged, the condenser might be damaged.

Condensing units can be stacked two high. It is recommended to keep the unit packaged until final installation. The condensing unit, when boxed, can be handled by a forklift or pallet truck. The condensing unit without the packaging must be handled by a forklift.

6. NextGen CoreSense

CoreSense is an ingredient brand name for compressor electronics associated with Copeland branded compressors. The CoreSense technology uses the compressor as a sensor to unlock information from within the compressor, providing value-added features such as advanced motor protection, diagnostics, power consumption measurement and communication.

Basic features	
Motor overheat protection	High discharge temperature protection
Insufficient oil pressure protection	Oil level protection (OM3) - not used
Current protection	Phase failure protection
Power consumption measurement	Under/over voltage protection
Crankcase heater control	Part winding protection
Switching frequency overstepping protection	Connection with computer
LEDs on terminal box cover	Reset button for manual reset

6.1 Warnings, trips and lockouts

Next Gen CoreSense module provides 3 different protection levels. Each of them has its own LED colour.

- **Warning alarms:** Compressor will continue to run.
- **Trip alarms:** Compressor turns off for defined time with automatic reset. If the compressor was stopped due to a fault condition, the compressor will restart when the fault condition is cleared and the defined off time has elapsed.
- **Lockout alarms:** Compressor turns off, manual reset is necessary. If the compressor was stopped due to a fault condition, the compressor will restart when the fault condition is cleared and a manual reset using the reset button is pressed. If a Modbus extension module is mounted, the reset can be done via Modbus.

6.2 Oil pressure protection

The Next Gen CoreSense module receives an input from the oil pressure differential sensor (OPS3) located in the oil pump. The module will issue a warning when the oil pressure differential falls below 0.95 bar for 4 seconds. Once the oil pressure differential falls below 0.95 bar for more than 2 minutes, the module will trip the compressor and a "low oil pressure lockout" will be reported. Before using the reset button, troubleshooting needs to be done to understand the failure. The compressor will switch ON once the CoreSense is manually reset.



6.3 Motor overheat protection

By using positive temperature coefficient (PTC) thermistors on 4M* and 6M* Stream compressor models, Next Gen CoreSense provides motor overheating protection. Two chains of three thermistors each connected in series are embedded in the motor windings.

Static overheat protection

The Next Gen CoreSense module will trip the compressor if the motor windings are getting too hot.

- **Standard condition:** Total resistance of the thermistor chains @ 25 °C \leq 1.8 k Ω
- **Alarm condition:**
Trip condition: PTC resistance > 4.5 k Ω ;
Reset condition: PTC resistance < 2.75 k Ω ; 5 min time delay.
- **Trip due to sensor failure:** Short circuit: PTC resistance < 20 Ω ; Open circuit: PTC resistance > 20k Ω . 5

Dynamic overheat protection

If the motor winding temperature increases in a short period (>240 Ω /400ms), the module will trip the compressor. The compressor will restart after 5 minutes.

6.4 High discharge temperature protection

Discharge temperature protection is provided using a PT1000 sensor in the compressor cylinder head.

The sensor is pre-installed at the factory and connected to the Next Gen CoreSense module. The module will protect the compressor from high discharge temperature conditions. If the temperature sensor detects a discharge temperature higher than 154 °C, the module will shut off the compressor until the temperature cools down to an acceptable level (20 K below setpoint).

The configurable range of trip settings is 108 °C to 154 °C and the reset value is 83 °C to 134 °C.

- Trip value \geq 154 °C for 0.5 sec
- Trip alarm: automatic reset after 2 minutes; discharge temp < 130 °C

PT1000 sensor technical data:

- Measuring range: -40°C to 155°C, 170°C for 30 minutes max
- Tightening torque: 15 Nm
- Protection class: IP65



6.5 Current protection

A current sensor is located in the terminal box.

One power supply wire (2 from the same phase in case of part-winding) is going through this sensor. The direction of the leads has to be respected



6.6 Locked rotor protection

If, 2.5 seconds after compressor start, the current is 150% of the MOC value, an alarm is triggered and the compressor trips. The alarm is reset after 5 minutes.

After 10 trips a lockout is activated and the Next Gen CoreSense module must be reset manually using the reset button (no automatic reset).

6.7 MOC protection

The MOC value of a compressor is stored into the Next Gen CoreSense module. The compressor trips if the measured current is higher than the MOC for more than 2 seconds.

This function starts 4.5 seconds after compressor start and resets automatically 5 minutes after tripping.

6.8 Switching frequency overstepping protection

The number of compressor starts is monitored over a defined period of time. If the compressor reaches the maximum number of starts in a time shorter than the defined one, an alarm is triggered.

Default setting is 10 starts in 1 hour and trip generation.

The reset time is calculated as the difference between the defined time period (1 hour) and the actual time it took for the defined maximum number of starts (10) to occur.

Example:

- 10 starts occurred in 35 minutes
- Alarm is triggered at 35 minutes
- Automatic reset will be done after 25 minutes
- It is possible to choose between a **warning** or compressor **trip**.
- MOC detection at first start
- Most compressors have two sets of nominal voltages and frequencies:
 - 1) 50 Hz or 60 Hz value for part-winding motors (AW...)
 - 2) Different voltages for Δ /Y start motors (EW...)

At first start and at every power reset, the Next Gen CoreSense module automatically detects the compressor power supply (voltage and frequency) and will automatically select the corresponding MOC and undervoltage/overvoltage protection setpoints.

If the measured voltage and/or frequency is different from the one defined on the nameplate, the module will generate a warning. For example, if an AWM/D (400 V / 50 Hz or 460 V / 60 Hz) motor is connected to a 230 V power line, the green LED will flash.

6.9 Phase / voltage monitoring

There are 6 voltage sensor circuits to measure the 3 phases. Thanks to the 6 sensors the part-winding motors can also be protected. The status of each phase in direct on-line and part-winding is monitored for undervoltage, overvoltage and phase asymmetry.

Missing phase protection / phase failure protection

A comparison is made between the voltage of each phase and their average. If any of the 3 power phases is missing after compressor start, a single-phasing condition exists.

Any voltage imbalance above 60 % is a condition for phase-loss trip.

Alarm conditions: occurs in case of missing phase conditions.

Trip time: 5 minutes with automatic reset.

A missing phase can be detected during start-up and when the compressor is running.

Undervoltage protection

Occurs when the compressor voltage is lower than the nominal supply voltage.

Low voltage warning condition: voltage < 85 % of the nominal line voltage for 2 seconds.

Low voltage trip conditions: voltage < 75 % of the nominal line voltage 2 seconds.

Trip time: 2 minutes.

Overvoltage protection

Occurs when the compressor voltage is higher than the nominal supply voltage.

High voltage warning condition: voltage > 115 % of the nominal line voltage for 2 seconds.

High voltage trip conditions: voltage > 125 % of the nominal line voltage for 2 seconds.

Trip time: 2 minutes.

Voltage imbalance protection

The purpose of this feature is to protect the compressor against a voltage imbalance that could lead to motor overheating.

A configurable setting (default = 5 %) for voltage imbalance is used to determine the operating limit of the compressor. The voltage imbalance setting is configurable in the range of 2 to 8 % using the Next Gen CoreSense module app.

Alarm conditions:

- **Warning:** when the voltage imbalance > 3 % (configurable).
- **Trip:** when the voltage imbalance > 5 % (configurable).
- **Reset:** automatic reset after 5 min; voltage imbalance < 5 %.

6.10 Part-winding protection

The two winding supply cables should go through the current sensor in the same direction. At first start or at power reset of the Next Gen CoreSense module, the voltage is measured on both windings.

If the voltages are identical:

- a. Compressor is connected in full winding, the protection is disabled.
- b. If the voltages are different, the voltages are compared again after 1 second.
- c. If the voltage on the second winding is the same as on the first winding, the compressor is connected in part-winding - the protection is enabled.
- d. If the voltage on the second winding is not the same as on the first winding, the second winding is improperly connected and the compressor trips.

The user has the possibility to select between a warning or trip condition. After a trip, the compressor will restart after 2 minutes. Default setting is trip.

6.11 LEDs on the terminal box cover

Status LEDs in 3 colours (green, orange and red) are visible on the top of the T-box



6.12 Compressor status codes

- a. Steady green: An indication of normal operation. There are no faults or issues with the compressor.
- b. Flashing green: An indication that there is a warning condition. The compressor keeps running.
- c. Steady orange: An indication that the compressor is in emergency mode.
- d. Flashing orange: An indication that the compressor has tripped and will automatically restart after a defined time (auto reset).
- e. Steady red: An indication that CoreSense is in parametrization mode.
- f. Flashing red: An indication that the compressor is locked out. Manual reset is needed for restart.

6.13 Failure alarms displayed by LEDs

Alarms are displayed via colored LEDs and flashing sequences. Every flash sequence is interrupted by a 2-second pause.

Chap	Flash code	Protection feature	Standard delivery	Standard settings			
				Compressor keeps running Warning	Automatic reset Trip	Manual reset required Lockout	Automatic reset after trip
5.1.1	1	Low oil pressure (oil pump)	X	< 0.95 bar after 4 sec		< 0.95 bar after 2 min	
5.1.2		Oil level protection (OM)	X	Selection possible	Oil level below 25 %		Correct oil level
5.2.1	2	Static motor overheat protection	X		PTC resistance > 4.5 kΩ		5 minutes and PTC resistance < 2.75kΩ
5.2.2		Dynamic motor overheat protection	X		> 240 Ω/400 ms		5 minutes
5.3	3	High discharge temperature (DLT)	X		154 °C		2 minutes and < 130 °C
5.4.1	4	Locked rotor protection	X		150 % of MOC	10 X Trip	5 minutes
5.4.2		Maximum operating current (MOC)	X		MOC		5 minutes
5.4.3		Switching frequency protection	X	Selection possible	10 starts/hour		When number of starts/set time period is lower than set value
5.4.4		MOC detection at first start	X	Voltage different from nameplate			
5.5.1	5	Missing phase protection	X		60 % of voltage imbalance		5 minutes
5.5.2		Undervoltage protection	X	< 85 % of nominal voltage for 2 sec	< 75 % of nominal voltage for 2 sec		2 minutes
5.5.3		Overvoltage protection	X	> 115 % of nominal voltage for 2 sec	> 125 % of nominal voltage for 2 sec		2 minutes
5.5.4		Voltage imbalance protection	X	Imbalance > 3 %	Imbalance > 5 %		5 minutes and min 2 % below setpoint
5.5.5		Welded contactor protection	X	No demand signal/current on one phase	Selection possible	10 X Trip	
5.5.6		Part-winding protection	X	Selection possible	Voltage difference after 1 sec		

Table 4: Flashing explanation

X = Disabled in standard delivery

6.14 Alarm history

The 20 most recent alarms are stored in the module memory and can be downloaded with the Next Gen CoreSense module app.

6.15 Reset button

Pressing the reset button is needed after a compressor lockout. In addition, it can be used for an immediate trip reset (no compressor waiting time to restart). If the tripping condition is cleared, all tripping counters are set to zero, the compressor can restart. If the tripping condition is not cleared, the reset signal is ignored.

6.16 CoreSense location

The Next Gen CoreSense module is located in the compressor terminal box. It is prewired to the oil pressure sensor (for compressors with oil pump), the motor thermistor chain (PTC), the discharge temperature sensor and the current sensor.



7. Electrical connections

Motor connections

Part-winding motors can be connected direct-on-line or part-winding start

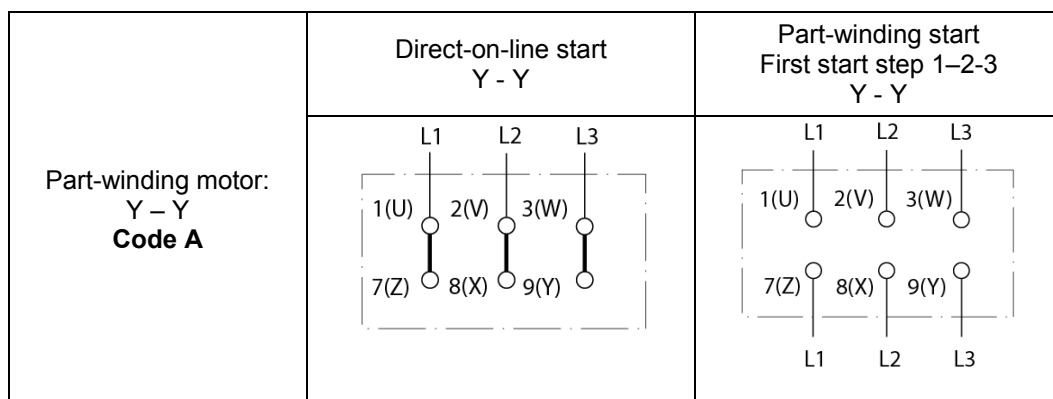

Star / Delta motors can be connected direct-on-line or Star / Delta start

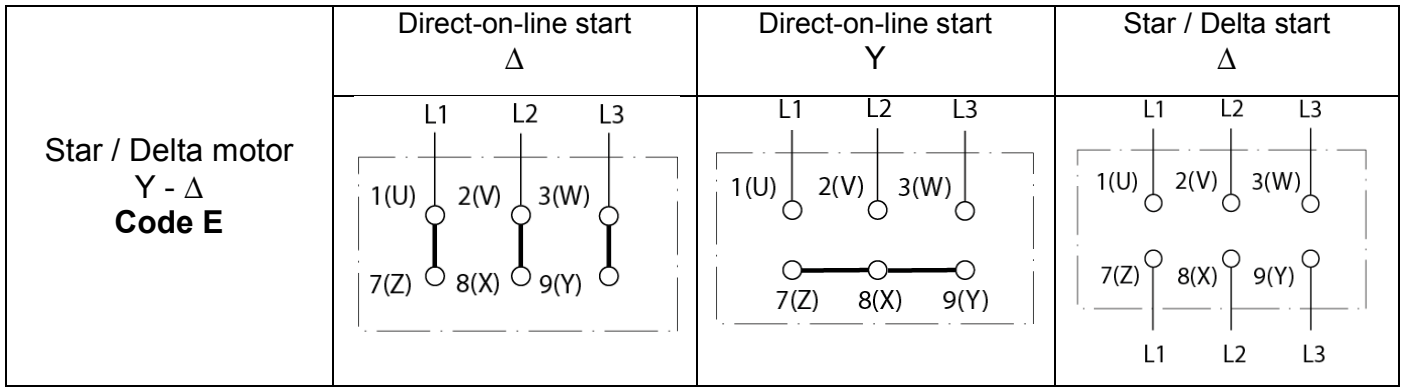

Compressor CoreSense/control wiring

052-3307-00 rev. 1

SEE ENCLOSURE
052-3307-00

4/6 COMPRESSOR & CO2 (4MTL-35/40/50)

Y-PART WINDING START (AWM/D-N, AWR-N, AWY-N, AWC-N, AWX-N)

NG CORESENSE MODULES, TERMINALS			
MODULE	TERMINAL	FUNCTION	
BASIC	1, 2	MODULE POWER SUPPLY	
	3, 4	OIL HEATER	
	5, 6	MOTOR PTC	
	7, 8	DISCHARGE GAS SENSOR	
	9, 10	CURRENT SENSOR	
	11, 12	OPS3	
	13, 14	RESET BUTTON	
	15, 16	DIGITAL OIL LEVEL INPUT FROM TRAXOIL	
	17, 18	DEMAND SIGNAL	
	19, 20,	ALARM RELAY (OPEN WHEN ALARM)	
	19, 21,	ALARM RELAY (CLOSE WHEN ALARM)	
	U1, V1, W1	PHASE MONITORING 1, 2, 3,	
	U2, V2, W2,	PHASE MONITORING 7, 8, 9,	
	FE	FUNCTIONAL EARTH	
	DP	DIAGNOSE PORT	
	A	-	BLUETOOTH DATA LOGGER
	A	-	REAL TIME CLOCK
	B	B1, B2, B3,	SUCTION PRESSURE SENSOR
		B4, B5, B6,	DISCHARGE PRESSURE SENSOR
B7, B8,		SUCTION TEMPERATURE	
C	C1, C2,	HEAD FAN	
	C2, C3,	LIQUID INJECTION	
	D1, D2,	UNLOADED START	
D	D2, D3,	DIGITAL CONTROL	
	D4, D5,	DEMAND INPUT	
	E	E1, E2, E3,	MODBUS
E4, E5, E6,			

MOTOR TERMINAL-BRIDGES CONFIGURATION

s1 | s2

Y-PART WINDING START

s1 | s2

YY-DIRECT START

NG CORESENSE DIAGNOSE LED FLASH CODES	
NUMBER OF FLASHING	FAILURE GROUP
1	OIL PROTECTION
2	MOTOR TEMPERA TURE
3	DLT MONITORING
4	CURRENT MONITORING
5	PHASE MONITORING
6	ENVELOPE MONITORING

The Next Gen CoreSense module is originally delivered with basic modules pre-connected.

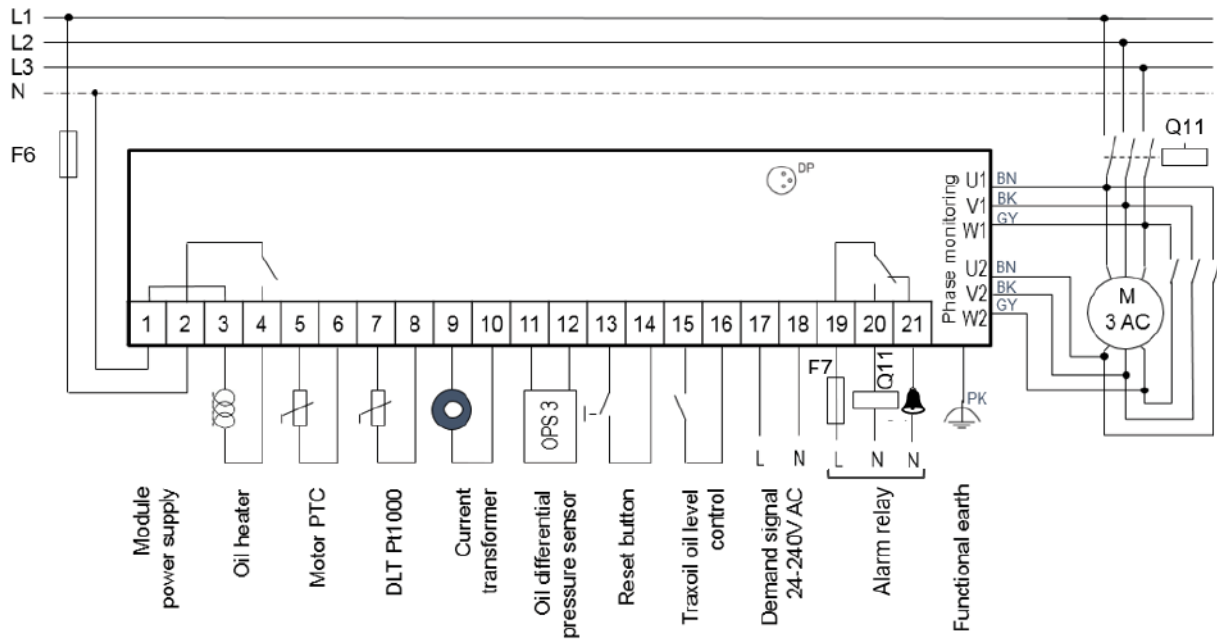

*1-2 Power supply, 19-20 control circuit & 17-18 welded contact alarm (optional)

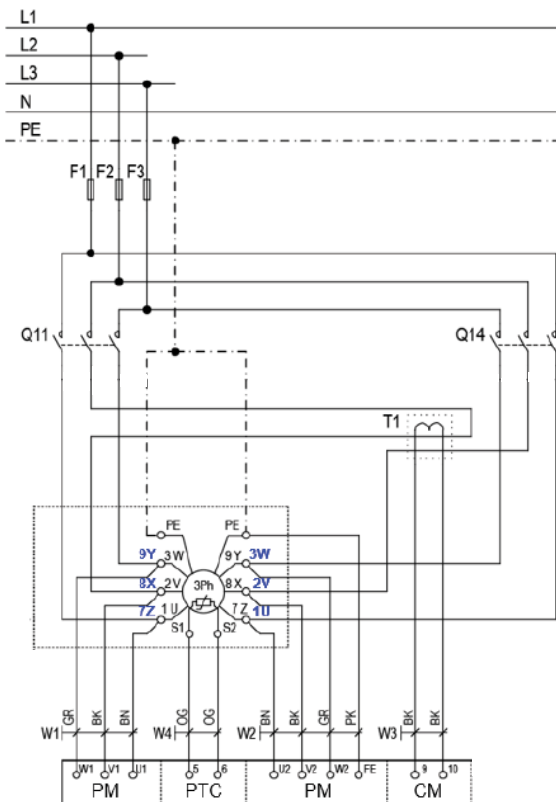

Part winding motors (AW...)

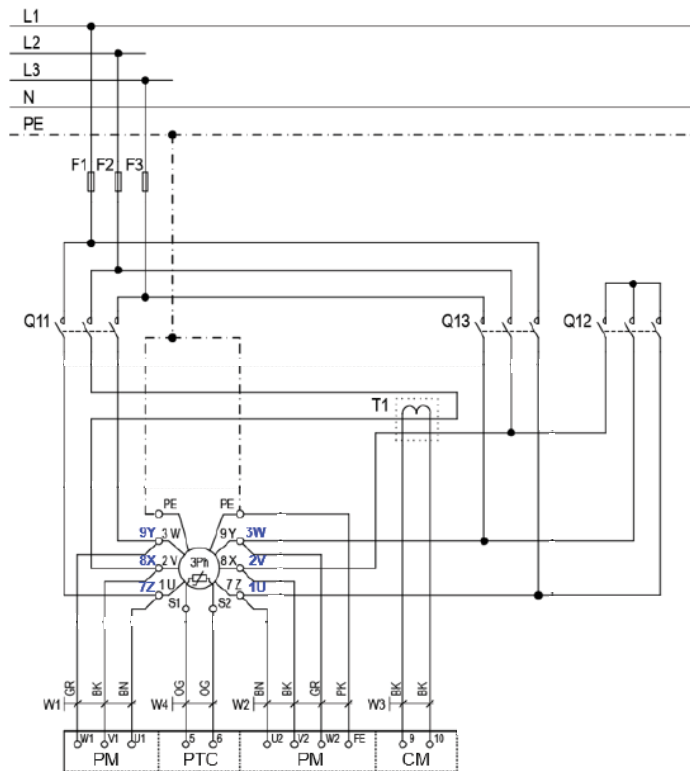

Star/Delta motors (EW...)

Z9 CDU: fan wiring

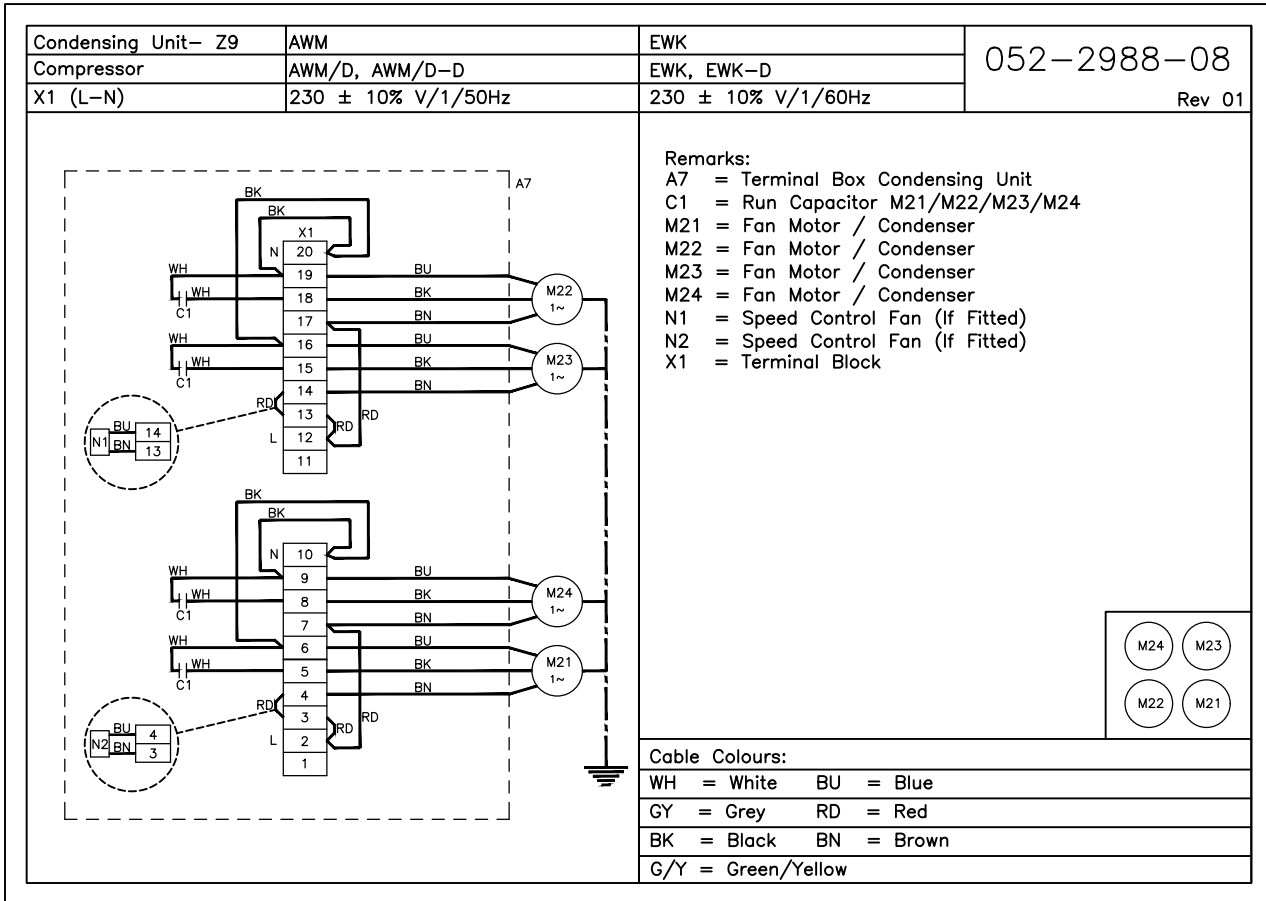

Z12 CDU: fan wiring

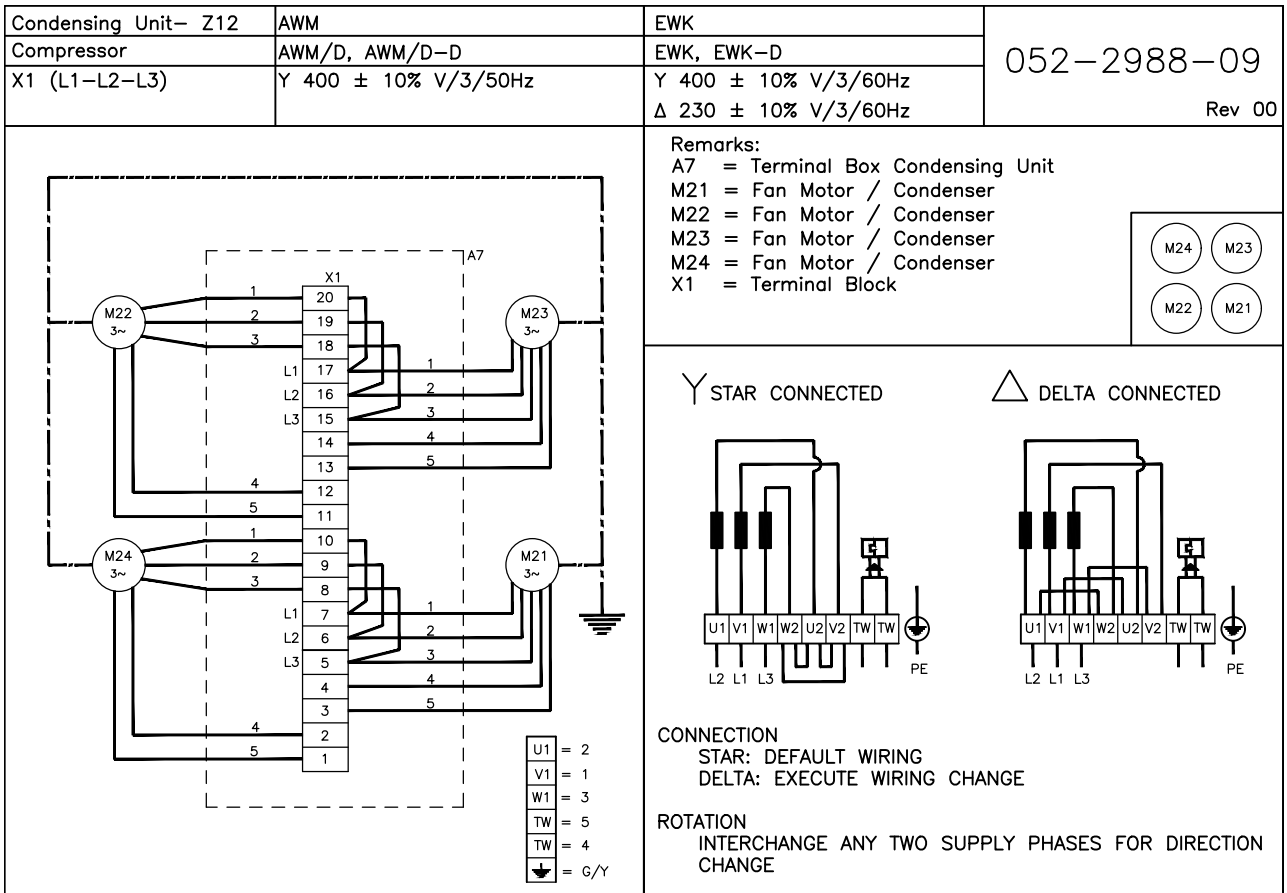

8. CDU performance/technical data

a. 50 Hz medium temperature

CDU Model	Z9-4MA-22X	Z9-4MH-25X	Z9-4MI-30X	Z9-4MJ-33X	Z12-4MK-35X	Z12-6MI-40X
Comp Model	4MA-22X	4MH-25X	4MI-30X	4MJ-33X	4MK-35X	6MI-40X
Capacity (kW)	26.6	30.2	32.8	35.3	41.9	49
Power Input (kW)	16.65	19.55	21.9	23.8	27.6	33.6
COP	1.597597598	1.544757033	1.497716895	1.483193277	1.518115942	1.458333333
Displacement (m ³ /hr)	61.7	71.4	78	87.5	99.5	120.5
Condenser Type/ Fan Qty	Z9/4	Z9/4	Z9/4	Z9/4	Z12/4	Z12/4
Air Flow (m ³ /sec)	5.41	5.41	5.41	5.41	7.5	7.5
Gross Weight (kg)	548	554	581	581	697	714
Net Weight (kg)	383	389	416	416	490	507
Dimension in mm (W*D*H)	1600*1107*873	1600*1107*1263	1600*1107*1263	1600*1107*1263	2001*1180*1406	2001*1180*1406
Suction Dia (")	1.625	2.125	2.125	2.125	2.125	2.125
Liquid Line (")	0.875	0.875	0.875	0.875	0.875	0.875
Receiver Capacity (L)	18.9	18.9	18.9	18.9	47.9	47.9
Condenser Fan Current (A)	1.85	1.85	1.85	1.85	1.35	1.35
Compressor MOC (A)	36.3	41.6	46.6	52.9	61.1	71.4
Compressor LRA	175	199	230	230	272	321

*R404A, evaporating -10°C, ambient 46°C, suction gas return 20°C, subcooling 0K

b. 50 Hz low temperature

CDU Model	W9-4MF-13X	W9-4ML-15X	W9-4MM-20X	Z9-4MT-22X	Z9-4MU-25X	Z9-6MM-30X	Z12-6MU-40X
Comp Model	4MF-13X	4ML-15X		4MT-22X	4MU-25X	6MM-30X	6MU-40X
Capacity (kW)	7.62	9.48	10.30	13.20	14.05	16.60	21.60
Power Input (kW)	9.82	11.85	13.15	15.40	17.00	20.80	26.30
COP	0.78	0.80	0.78	0.86	0.83	0.80	0.82
Displacement (m ³ /hr)	61.70	71.40	78.00	87.50	99.50	120.50	153.00
Condenser Type/ Fan Qty	W9/2	W9/2	W9/2	Z9/4	Z9/4	Z9/4	Z12/4
Air Flow (m ³ /sec)	3.33	3.33	3.33	5.41	5.41	5.41	7.50
Gross Weight (kg)	434.00	434.00	434.00	554.00	557.00	575.00	720.00
Net Weight (kg)	320.00	320.00	320.00	389.00	392.00	410.00	513.00
Dimension in mm (W*D*H)	1600*1107*873	1600*1107*873	1600*1107*875	1600*1107*1263	1600*1107*1263	1600*1130*1263	2001*1180*1406
Suction Dia (")	1.63	1.63	2.13	2.13	2.13	2.13	2.13
Liquid Line (")	0.88	0.88	0.88	0.88	0.88	0.88	0.88
Receiver Capacity (L)	18.90	18.90	18.90	18.90	18.90	18.90	47.90
Condenser Fan Current (A)	1.85	1.85	1.85	1.85	1.85	1.85	1.35
Compressor MOC (A)	30.80	35.40	39.00	44.50	51.90	59.70	75.80
Compressor LRA	105.00	156.00	175.00	175.00	199.00	255.00	306.00

*R404A, evaporating -30°C, ambient 46°C, suction superheat 10K, subcooling 0K

c. 60 Hz medium temperature

CDU Model	Z9-4MA-22X	Z9-4MH-25X	Z12-4MI-30X	Z12-4MJ-33X	Z12-4MK-35X	Z12-6MI-40X
Comp Model	4MA-22X	4MH-25X	4MI-30X	4MJ-33X	4MK-35X	6MI-40X
Capacity (kW)	31	35.1	41.2	44.6	48.5	56.5
Power Input (kW)	19.75	23.2	27.5	29.8	33.8	41.2
COP	1.57	1.51	1.50	1.50	1.43	1.37
Displacement (m ³ /hr)	74.50	86.00	94.50	106.00	120.00	145.50
Condenser Type/ Fan Qty	Z9/4	Z9/4	Z12/4	Z12/4	Z12/4	Z12/4
Air Flow (m ³ /sec)	5.41	5.41	7.5	7.5	7.5	7.5
Gross Weight (kg)	548	554	683	685	697	714
Net Weight (kg)	383	389	476	478	490	507
Dimension in mm (W*D*H)	1600*1107*873	1600*1107*1263	2001*1180*1406	2001*1180*1406	2001*1180*1406	2001*1180*1406
Suction Dia (")	1 5/8	2 1/8	2 1/8	2 1/8	2 1/8	2 1/8
Liquid Line (")	7/8	7/8	7/8	7/8	7/8	7/8
Receiver Capacity (L)	18.9	18.9	47.9	47.9	47.9	47.9
Condenser Fan Current (A)	2.25	2.25	1.35	1.35	1.35	1.35
Compressor MOC (A)	45.7	52.4	58.7	66.7	77	90
Compressor LRA	234	260	290	290	363	418

*R404A, evaporating -10°C, ambient 46°C, suction gas return 20°C, subcooling 0K

d. 60 Hz low temperature

CDU Model	W9-4MF-13X	Z9-4ML-15X	Z9-4MM-20X	Z9-4MT-22X	Z9-4MU-25X	Z9-6MM-30X
Comp Model	4MF-13X	4ML-15X	4MM-20X	4MT-22X	4MU-25X	6MM-30X
Capacity (kW)	8.69	12.65	14.00	15.35	16.35	19.25
Power Input (kW)	11.65	14.70	16.30	18.20	20.10	24.70
COP	0.75	0.86	0.86	0.84	0.81	0.78
Displacement (m ³ /hr)	74.50	86.00	94.50	106.00	120.00	145.50
Condenser Type/ Fan Qty	W9/2	Z9/4	Z9/4	Z9/4	Z9/4	Z9/4
Air Flow (m ³ /sec)	3.33	5.41	5.41	5.41	5.41	5.41
Gross Weight (kg)	434.00	551.00	553.00	554.00	557.00	575.00
Net Weight (kg)	320.00	386.00	388.00	389.00	392.00	410.00
Dimension in mm (W*D*H)	1600*1107*873	1600*1107*1263	1600*1107*1263	1600*1107*1263	1600*1107*1263	1600*1130*1263
Suction Dia (")	1.63	1.63	2.13	2.13	2.13	2.13
Liquid Line (")	0.88	0.88	0.88	0.88	0.88	0.88
Receiver Capacity (L)	18.90	18.90	18.90	18.90	18.90	18.90
Condenser Fan Current (A)	2.25	2.25	2.25	2.25	2.25	2.25
Compressor MOC (A)	38.80	44.60	49.10	56.10	65.40	75.20
Compressor LRA	132.00	194.00	224.00	224.00	252.00	320.00

*R404A, evaporating -30°C, ambient 46°C, suction superheat 10K, subcooling 0K

9. Installation, system processing and commissioning

a. Inspection

Inspect the condensing unit and any accessories shipped with them for damages or shortages before and during unloading. All items on bill of lading should be accounted for prior to signing the shipping receipt. Note any shortages or damage on delivery receipt (specify the extent and type of damage found). Unit should be inspected carefully for concealed damage. Notify Copeland sales/application personnel of the damage immediately. Request an immediate joint inspection and do not repair the unit until inspected by Copeland's representative.

The system is shipped with a holding charge of dry nitrogen. Check to see that pressure is still in the unit upon receipt. Report lack of pressure immediately to the Copeland's application/sales representative.

b. Installation base

- The unit should always be installed in a location that ensures clean air flow. Both service access and airflow have been considered in making these recommendations.
- Where multiple units are installed, due care should be taken to avoid the discharge air from each unit adversely affecting other units in the vicinity.
- Ideally, the unit should be mounted on a solid concrete slab with anti-vibration pads between unit feet and concrete.
- Ensure that there is no obstruction to air flow into or out of the unit. Remove obstacles which block air intake or discharge
- The location must be well ventilated, so the air can pass properly through condenser by maintaining the proper condensation in the system.
- To optimize the unit running conditions, the condenser coil must be cleaned at regular intervals

c. Installation clearance

It is recommended to have a minimum clearance of 800 mm between the condenser face and adjacent wall, while a minimum clearance of 1600 mm between two adjacent units for service and sufficient air circulation.

d. Refrigeration piping installation

All interconnecting pipes should be of refrigeration grade, clean, dehydrated and must remain capped at both ends until installation. Even during installation, if the system is left for any reasonable period (say two hours), pipes should be re-capped to prevent moisture and contaminants from entering the system.

Do not assume that the service connection sizes on the unit (at the service valves) are the correct size to run your interconnecting refrigeration pipes. The service valve sizes have been selected for convenience of installation and in some cases (larger units) these may be considered too small. However, for the very short pipe run within our units, these service connection sizes are adequate.

The pipe should be sized to ensure optimum performance and proper oil return. The sizing must also consider the full capacity range through which this particular unit will need to operate.

Pipe runs should be kept as short as possible, using the minimum number of directional changes. Use large radius bends and avoid trapping of oil and refrigerant. This is particularly important for the suction line. The suction line should ideally slope gently towards the unit. Recommendation slope is 1/200~1/250. P traps, double risers and reduced pipe diameters may be required for suction lines where long vertical risers cannot be avoided. All pipes should be adequately supported to prevent sagging which can create oil traps.

The recommended pipe clamp support distance is shown in the table.

Tube size	Max distance between 2 clamp support
1/2 inch	1.2 M
5/8 inch	1.5 M
7/8 inch	1.85 M
1 1/8 inch	2.2 M

e. Refrigerant line insulation

- Insulate suction lines from the evaporators to the condensing unit with minimum 1" thickness closed-cell type insulation on low temperature circuits.
- Long liquid lines run in areas exposed to high temperatures should be fully insulated with minimum 1/2" insulation.
- Suction and liquid lines should never be taped or soldered together.

f. Electrical

- All electrical work must be done in accordance with the National Electrical Code and existing local codes.
- Power supply must be the same as specified on the unit name plate.
- Voltage fluctuations in excess of 10 percent must be corrected.
- Breaker to be selected in accordance with specified limits, they must not be changed in size or shorted-out.
- Before starting the unit, ensure that all protective devices are in place and that all wiring is secure.

g. Brazing recommendation

Maintain a flow of oxygen-free nitrogen through the system at a very low-pressure during brazing. Nitrogen displaces the air and prevents the formation of copper oxides in the system. If copper oxidization is allowed to form, the copper oxide material can later be swept through the system and block screens such as those protecting capillary tubes, thermal expansion valves, and accumulator oil return holes. This minimizes any entry of contaminants and moisture.

h. Start-up & operation

Initial pressure test (by vacuum and nitrogen)

Step-by-step

- Use a 4-port gauge manifold with 3/8" hose and connections to the vacuum pump. The vacuum gauge does not have to be connected for this part of the process.
- Connect the gauges to service ports provided on receiver valve and suction tube. In order to remove any non-condensable that may have entered the system during installation, follow these steps:
- Start the vacuum pump. The evaporator fan should be running and the compressor crankcase heater is energized at this point. This will involve powering up the unit so it is important to disconnect the live feed wire to the compressor contactor (so the compressor cannot run and the crankcase heater can be energized).
- Open both valves on the manifold and then open the main vacuum valve on the pump. Run the system until the vacuum level of -0.85 bar (as read on manifold gauge) is achieved.
- Shut off the main vacuum pump valve. Check for vacuum rise using the manifold compound gauge. A rise would indicate a large leak.
- If vacuum holds for 10 minutes, break vacuum with nitrogen and pressurize to 20 bar. Check for leaks and repair leakage.

Leak check

The success of all the subsequent commissioning depends on a leak free system, free of contaminants, free of oxides, free of non-condensables, that has been evacuated to a low vacuum and charged with the prescribed refrigerant.

Leak test is particularly important for field-connected systems. Typically, field systems lose as much as 20%-30% of their refrigeration charge annually. This is not only an unnecessary expense but also damages the environment. Compressor oil can be lost at the same time as refrigerant and eventually lead to compressor failure. (Time spent on leak test will eventually reduce the time spent on the evacuation process).

Ensure that all service valves are open during the leak test process. It is important to recheck all joints within the unit as well as the external joints.

- a. The unit is shipped with a holding charge of dry nitrogen and should be leak free.
- b. Ensure that the test pressure do not exceed the system design pressures.
- c. Do not expose system pressure controls HP/LP to test pressures above their design pressure. This can damage the pressure controls.
- d. Using an approved, calibrated electronic gas leak detector, leak test the entire system paying attention to all joints.
- e. Periodically check functionality of the electronic leak detector during this process.
- f. To further check system integrity, spray a soapy water solution over joins then visually inspect for bubbles.
- g. Leave the system under pressure for a designated period (24 Hours).
- h. Check and record the ambient temperatures and the system pressure with calibrated approved instruments. This process is to be carried out every 8-12 hours during the pressure testing process.
- i. If the test pressures cannot be maintained, repeat the leak testing process employing the isolation of sections of the system to determine the source of leaks. Repair the leak and repeat the leak testing process until system can be signed off as leak free and approved by authorized personnel.
- j. Record findings and confirm pressure testing process completion.

Evacuation

- a. After the system is leak checked, connect approved dual stage vacuum pump sized to application with fresh oil to evacuation valve.
- b. Ensure all inline system shut-off valves and solenoid valves are fully open.
- c. Evacuate the system to 300 microns.
- d. A triple evacuation is recommended. The third and final evacuation should achieve a value of 300 microns or less. After this vacuum is reached, system is ready for refrigerant charging and add as much refrigerant as possible into the receiver.

Charging and commissioning

Step-by-step

1. Ensure that there is no power supply to the unit. Hence, it is acceptable to leave the crankcase heater off.
2. Connect the refrigerant cylinder to main service hose and purge line at the manifold end.
3. Invert the refrigerant cylinder if necessary to ensure only liquid refrigerant can be charged into the system. This will be charged through the high pressure side of the manifold and liquid service valve.
4. The refrigerant cylinder should be weighed at this point to be able to record the final refrigerant charge.
5. Now open the liquid service valve (off the back seat). In warm ambient, with a good vacuum in the system and the refrigerant cylinder inverted, it may not be necessary to run the compressor.
6. In cooler ambient, it may be necessary to run the compressor in order to complete charging. Steam compressor systems should be charged as quickly as possible by bleeding liquid refrigerant into the suction line with the compressor running.
7. The system needs to be operated down to its set point before you can be sure that the charge is correct. It is at this point that the normal refrigeration operational checks can be carried out—such as checking the liquid line sight glass for bubbles and the operating pressures.
8. If the system is still short of the refrigerant, bleed liquid refrigerant into the suction side with the compressor running.
9. Check the oil level and add oil if necessary.

Oil charging

- a. Check the oil level of compressor viewing the oil level controls oil sight glass.
- b. Pump additional oil into the compressor to a maximum 1/2 sight glass level.

Unit operation

Before starting the unit, ensure the following:

- a. All the electrical connections are correct and as per the recommended wiring diagrams.
- b. All low side tubing is properly insulated.
- c. Leak check is completed and unit is pre-charged with refrigerant through high side.
- d. Check for superheat setting on the expansion valve (TXV) appropriate or not.

Adding refrigerant on a cold weather results to an overcharged unit, which may then trip out on high pressure limit during warm weather.

Suction superheat should be 10–15 K for reliable operation.

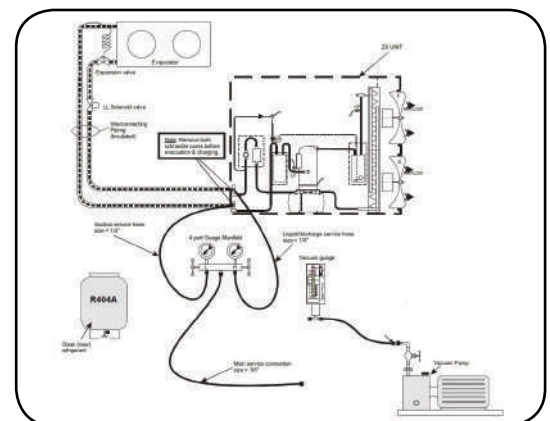



Remember that the refrigerant is under pressure. Always wear protective equipment, i.e. safety glasses or goggles and gloves when working with refrigerant, and guard against refrigerant spraying into the face or skin. Line pressures on an operating conditioning unit will vary with outdoor temperatures. As outdoor temperatures rise, pressures will also rise.

Caution



DO NOT, UNDER ANY CIRCUMSTANCES, HEAT THE REFRIGERANT CYLINDER WITH A TORCH OR BY ANY OTHER MEANS OTHER THAN WARM WATER. EXCESSIVE PRESSURES GENERATED IN THIS MANNER MAY WEAKEN THE REFRIGERANT CONTAINER AND RESULT TO A CYLINDER EXPLOSION!

i. Maintenance

Condenser fins

Condenser fins become dirty over time as ambient air is induced to the condenser. Dirty coil surfaces result in high condensing temperatures and poor unit performance. Regular cleaning is recommended with frequency depending on the installation and the surrounding environment. As a general guide, it is advisable to do this at least once every two months.

Fins should be cleaned with liquid detergent diluted with clean water. Before washing, a light brush downward (in the direction of the fins) should be done to remove heavy deposits.

Electrical connections

Check tightness of electrical connections occasionally.

Routine leak test

All joints should be checked for leaks during site visits. All joints should be leak tested once a year. Condenser fan(s) and motor(s), an annual inspection of these items is recommended. Fastenings may loosen, bearings may wear, and fans may require cleaning of solid deposits which can cause imbalance.



TURN OFF OR DISCONNECT THE ELECTRICAL POWER SOURCE BEFORE CLEANING THE CONDENSER COIL OR DOING MAINTENANCE.

10. Commissioning report

A permanent data sheet should be prepared on each installation, with a copy for the owner and the original for the installing contractor. If another firm is to handle service and maintenance, additional copies should be prepared as necessary.

System reference data

The following information should be filled out and signed by the refrigeration installation contractor.

Date system installed:

Date started:

Installer contact details:

Job name / location:

Condensing unit model no.:

Condensing unit serial no.:

Compressor model no.:

Compressor serial no.:

Electrical power input:

Refrigerant:

Evacuation: # times

Final micron:

System suction pressure:

System discharge pressure:

Ambient temperature:

Room temperature during measurement:

Voltage:	L1-L2	L2-L3	L3-L1
Compressor current:	L1	L2	L3
CDU current:	L1	L2	L3

We hereby acknowledge that the condensing unit is performing as specified.

Prepared by:

Confirmed by:

Date:

Date:



About Copeland

Copeland is a global leader in sustainable heating, cooling, refrigeration and industrial solutions. We help commercial, industrial, refrigeration and residential customers reduce their carbon emissions and improve energy efficiency. We address issues like climate change, growing populations, electricity demands and complex global supply chains with innovations that advance the energy transition, accelerate the adoption of climate friendly low GWP (Global Warming Potential) and natural refrigerants, and safeguard the world's most critical goods through an efficient and sustainable cold chain. We have over 18,000 employees, with feet on the ground in 50 countries - a global presence that makes it possible to serve customers wherever they are in the world and meet challenges with scale and speed. Our industry-leading brands and diversified portfolio deliver innovation and technology proven in over 200 million installations worldwide. Together, we create sustainable solutions that improve lives and protect the planet today and for future generations. For more information, visit copeland.com.

Follow us:



To learn more, visit copeland.com

(2021/MEA/73) Steam condensing unit user manual.
8530152 ©2024 Copeland LP.

COPELAND